



COMMISSION OF THE EUROPEAN COMMUNITIES

Brussels, 5.9.2006
COM(2006) 478 final

2006/0161 (COD)

Proposal for a

DIRECTIVE OF THE EUROPEAN PARLIAMENT AND OF THE COUNCIL

**relating to the space for mounting the rear registration plate of two or three-wheel
motor vehicles**

(Codified version)

(presented by the Commission)

EXPLANATORY MEMORANDUM

1. In the context of a people's Europe, the Commission attaches great importance to simplifying and clarifying Community law so as to make it clearer and more accessible to the ordinary citizen, thus giving him new opportunities and the chance to make use of the specific rights it gives him.

This aim cannot be achieved so long as numerous provisions that have been amended several times, often quite substantially, remain scattered, so that they must be sought partly in the original instrument and partly in later amending ones. Considerable research work, comparing many different instruments, is thus needed to identify the current rules.

For this reason a codification of rules that have frequently been amended is also essential if Community law is to be clear and transparent.

2. On 1 April 1987 the Commission therefore decided¹ to instruct its staff that all legislative acts should be codified after no more than ten amendments, stressing that this is a minimum requirement and that departments should endeavour to codify at even shorter intervals the texts for which they are responsible, to ensure that the Community rules are clear and readily understandable.

3. The Conclusions of the Presidency of the Edinburgh European Council (December 1992) confirmed this², stressing the importance of codification as it offers certainty as to the law applicable to a given matter at a given time.

Codification must be undertaken in full compliance with the normal Community legislative procedure.

Given that no changes of substance may be made to the instruments affected by codification, the European Parliament, the Council and the Commission have agreed, by an interinstitutional agreement dated 20 December 1994, that an accelerated procedure may be used for the fast-track adoption of codification instruments.

4. The purpose of this proposal is to undertake a codification of Council Directive 93/94/EEC of 29 October 1993 relating to the space for mounting the rear registration plate of two or three-wheel vehicles³. The new Directive will supersede the various acts incorporated in it⁴; this proposal fully preserves the content of the acts being codified and hence does no more than bring them together with only such formal amendments as are required by the codification exercise itself.

¹ COM(87) 868 PV.

² See Annex 3 to Part A of the Conclusions.

³ Carried out pursuant to the Communication from the Commission to the European Parliament and the Council – Codification of the Acquis communautaire, COM(2001) 645 final.

⁴ See Annex II, Part A of this proposal.

5. The codification proposal was drawn up on the basis of a preliminary consolidation, in all official languages, of Directive 93/94/EEC and the instrument amending it, carried out by the Office for Official Publications of the European Communities, by means of a data-processing system. Where the Articles have been given new numbers, the correlation between the old and the new numbers is shown in a table contained in Annex III to the codified Directive.

Proposal for a

DIRECTIVE OF THE EUROPEAN PARLIAMENT AND OF THE COUNCIL

relating to the space for mounting the rear registration plate of two or three-wheel motor vehicles

(Text with EEA relevance)

THE EUROPEAN PARLIAMENT AND THE COUNCIL OF THE EUROPEAN UNION,

Having regard to the Treaty establishing the European Community, and in particular Article 95 thereof,

Having regard to Directive 2002/24/EC of the European Parliament and of the Council of 18 March 2002 relating to the type-approval of two or three-wheel motor vehicles and repealing Council Directive 92/61/EEC⁵,

Having regard to the proposal from the Commission,

Having regard to the opinion of the European Economic and Social Committee⁶,

Acting in accordance with the procedure laid down in Article 251 of the Treaty⁷,

Whereas:

- (1) Council Directive 93/94/EEC of 29 October 1993 relating to the space for mounting the rear registration plate of two or three-wheel vehicles⁸ laid down technical prescriptions concerning the design and construction of two or three-wheel motor vehicles as regards the space for mounting the rear registration plate. These technical prescriptions concerned the approximation of the laws of the Member States to allow for the EC type-approval procedure provided for in Directive 2002/24/EC to be applied in respect of each type of vehicle. Directive 93/94/EEC has been substantially amended⁹. In the interests of clarity and rationality the said Directive should be codified.

⁵ OJ L 124, 9.5.2002, p. 1. Directive as last amended by Commission Directive 2005/30/EC (OJ L 106, 27.4.2005, p. 17).

⁶ OJ C [...], [...], p. [...].

⁷ OJ C [...], [...], p. [...].

⁸ OJ L 311, 14.12.1993, p. 83. Directive as amended by Commission Directive 1999/26/EC (OJ L 118, 6.5.1999, p. 32).

⁹ See Annex II, Part A.

- (2) This Directive is one of the separate Directives of the EC type-approval system provided for in Directive 2002/24/EC. Consequently, the provisions laid down in Directive 2002/24/EC relating to vehicle systems, components and separate technical units apply to this Directive.
- (3) The objective of this Directive is not to harmonise the dimensions of registration plates used in the various Member States. The Member States should therefore ensure that protruding registration plates do not constitute a danger for users, without, however, this requiring any modification with regard to vehicle construction.
- (4) This Directive should be without prejudice to the obligations of the Member States relating to the time-limits for transposition into national law and application of the Directives set out in Annex II, Part B,

HAVE ADOPTED THIS DIRECTIVE:

Article 1

This Directive shall apply to the space for mounting the rear registration plate of all types of motor vehicle as defined in Article 1 of Directive 2002/24/EC.

Article 2

The procedure for the granting of EC component type-approval in respect of the space for mounting the rear registration plate for a type of two or three-wheel motor vehicle and the conditions governing the free movement of such vehicles shall be as laid down in Chapters II and III of Directive 2002/24/EC.

Article 3

The amendments necessary to adapt the requirements of Annex I to this Directive to take account of technical progress shall be adopted in accordance with the procedure referred to in Article 13 (3) of Directive [70/156/EEC].

Article 4

Member States shall communicate to the Commission the texts of the provisions of national law which they adopt in the field covered by this Directive.

Article 5

Directive 93/94/EEC, as amended by the Directive listed in Annex II, Part A, is repealed, without prejudice to the obligations of the Member States relating to the time-limits for transposition into national law and application of the Directives set out in Annex II, Part B.

References to the repealed Directive shall be construed as references to this Directive and shall be read in accordance with the correlation table set out in Annex III.

Article 6

This Directive shall enter into force on the twentieth day following that of its publication in the *Official Journal of the European Union*.

It shall apply from [...].

Article 7

This Directive is addressed to the Member States.

Done at Brussels, [...]

For the European Parliament
The President
[...]

For the Council
The President
[...]

ANNEX I

1. DIMENSIONS

The dimensions of the space for mounting the rear registration plate of two or three-wheel motor vehicles¹⁰ are as follows:

1.1. Mopeds and light quadricycles without a body

1.1.1. *Width:* 100 mm;

1.1.2. *Height:* 175 mm;

or

1.1.3. *Width:* 145 mm;

1.1.4. *Height:* 125 mm.

1.2. Motorcycles, tricycles up to a maximum power of 15 kW and quadricycles, other than light quadricycles, without a body

1.2.1. *Width:* 280 mm;

1.2.2. *Height:* 210 mm.

1.3. Tricycles with a maximum power exceeding 15 kW, light quadricycles fitted with a body and quadricycles other than light quadricycles fitted with a body

1.3.1. The provisions for passenger cars as set out in Council Directive 70/222/EEC¹¹ shall apply.

2. GENERAL LOCATION

2.1. The mounting for the rear registration plate of a motorcycle, motorcycle combination or tricycle must be located at the rear of the vehicle in such a manner that:

2.1.1. the plate can be positioned within the longitudinal planes passing through the outer extremities of the vehicle.

¹⁰ In the case of mopeds, this is any registration and/or identification plate.

¹¹ OJ L 76, 6.4.1970, p. 25.

3. INCLINATION

3.1. The rear registration plate:

3.1.1. must be at right angles to the median longitudinal plane of the vehicle;

3.1.2. may be inclined from the vertical by not more than 30°, with the vehicle unladen, when the backing plate for the registration number faces upwards;

3.1.3. may be inclined by not more than 15° from the vertical, with the vehicle unladen, when the backing plate for the registration number faces downwards;

4. MAXIMUM HEIGHT

4.1. No point on the space for mounting the registration plate may be more than 1,5 m above the ground when the vehicle is unladen.

5. MINIMUM HEIGHT

5.1. No point on the space for mounting the registration plate shall be less than 0,20 m above the ground or less than the radius of the wheel above the ground if that is less than 0,20 m, when the vehicle is unladen.

6. GEOMETRIC VISIBILITY

6.1. The space for mounting the plate must be visible within a space bordered by two dihedrals: one with a horizontal edge defined by two planes passing through the upper and lower horizontal edges of the space for mounting the plate, the angles of which in relation to the horizontal are shown in Figure 1; the other with a perceptibly vertical edge defined by two planes passing through each side of the plate, the angles of which in relation to the median longitudinal plane of the vehicle are shown in Figure 2.

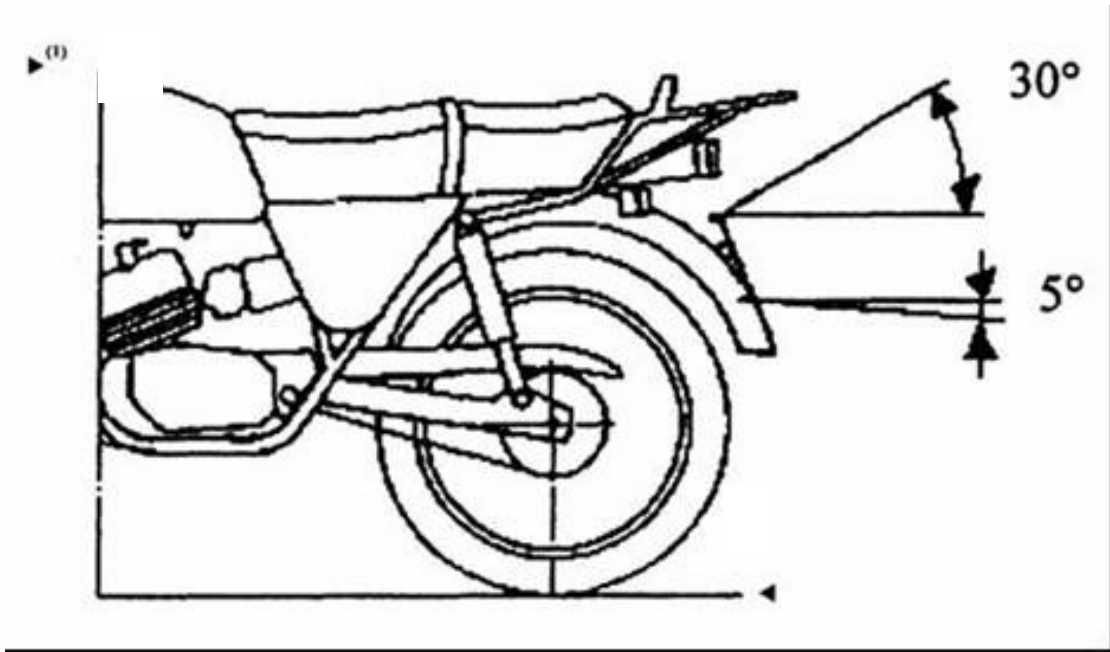

Figure 1

Angle of geometric visibility (dihedral with horizontal edge)

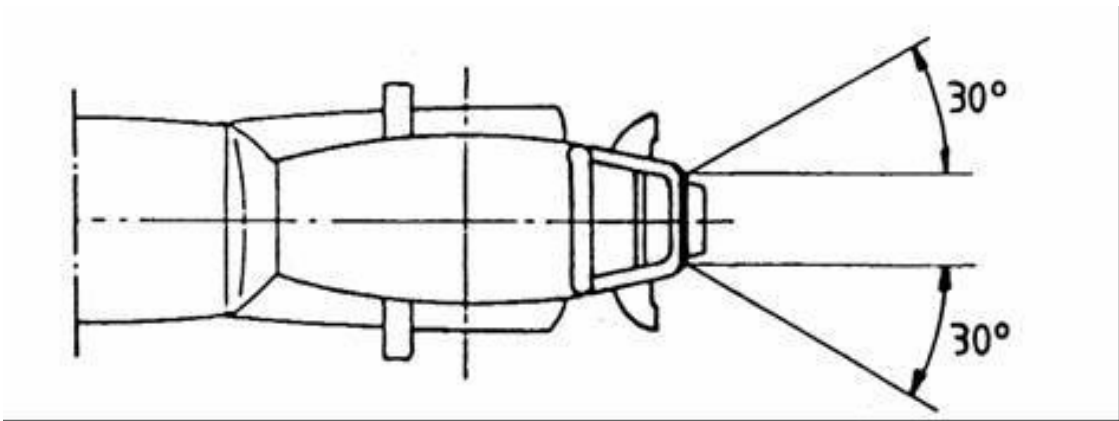

Figure 2

Angle of geometric visibility (dihedral with perceptibly vertical edge)

Appendix 1

Information document in respect of the space for mounting the rear registration plate of a type of two or three-wheel motor vehicle

(to be attached to the application for EC component type-approval where this is submitted separately from the application for EC vehicle type-approval)

Order No (assigned by the applicant):

The application for EC component type-approval in respect of the space for mounting the rear registration plate of a type of two or three-wheel motor vehicle must contain the information set out in Annex II to Directive 2002/24/EC, Part A, sections:

- 0.1,
 - 0.2,
 - 0.4 to 0.6,
 - 2.2,
 - 2.2.1,
 - 9.6,
 - 9.6.1.
-

Appendix 2

Name of administration

Component type-approval certificate in respect of the space for mounting the rear registration plate of a type of two or three-wheel motor vehicle

MODEL

Report No by technical service date

Compon 1. Trade mark or name of vehicle Extension No

1. Trade mark of name of vehicle

2. Vehicle type

3. Manufacturer's name and address

4. Name and address of manufacturer's representative (if any)

5. Date vehicle submitted for test

6. Component type-approval has been granted/refused ⁽¹⁾.

7. Place

8. Date

9. Signature

(¹) Delete as appropriate.

ANNEX II

Part A

Repealed Directive with its amendment (referred to in Article 5)

Council Directive 93/94/EEC (OJ L 311, 14.12.1993, p. 83)

Commission Directive 1999/26/EC (OJ L 118, 6.5.1999, p. 32)

Part B

List of time-limits for transposition into national law and application (referred to in Article 5)

Directive	Time-limit for transposition	Date of application
93/94/EEC	30 April 1995	1 November 1995 ⁽¹⁾
1999/26/EC	31 December 1999	1 January 2000 ⁽²⁾

⁽¹⁾ In conformity with Article 4 of Directive 93/94/EEC:

“From [1 May 1995], Member States may not, for reasons connected with the space for mounting the rear registration plate, prohibit the initial entry into service of vehicles which conform to this Directive.”

⁽²⁾ In conformity with Article 2 of Directive 1999/26/EC:

“1. With effect from 1 January 2000, Member States shall not, on grounds relating to the space for mounting the rear registration plate:

- refuse, in respect of a type of two or three-wheel vehicle, to grant EC type-approval,
- prohibit the registration, sale or entry into service of two or three-wheel motor vehicles,

if the space for mounting the rear registration plate complies with the requirements of Directive 93/94/EEC as amended by this Directive.

2. With effect from 1 July 2000, Member States shall refuse to grant EC type-approval for any type of two or three-wheel motor vehicle on grounds relating to the space for mounting the rear registration plate if the requirements of Directive 93/94/EEC, as amended by this Directive, are not fulfilled.”

ANNEX III

CORRELATION TABLE

Directive 93/94/EEC	This Directive
Articles 1, 2 and 3	Articles 1, 2 and 3
Article 4(1)	—
Article 4(2)	Article 4
—	Article 5
—	Article 6
Article 5	Article 7
Annex	Annex I
—	Annex II
—	Annex III